

**COLD AIR INSTANTLY  
USING ONLY COMPRESSED AIR**

**Arizona Vortex–Vortex Tubes**

**TEMPERATURES FROM  
-50 DEGREES F. TO 260 DEGREES F.  
UP TO 2500 BTUH  
FLOW RATES UP TO 35 SCFM**

An Arizona Vortex Tube is a device with no moving parts that will convert an ordinary stream of compressed air into two streams—one hot and one cold. A Vortex Tube can produce cold air down to -50 degree F. and hot air up to 260 degree F.

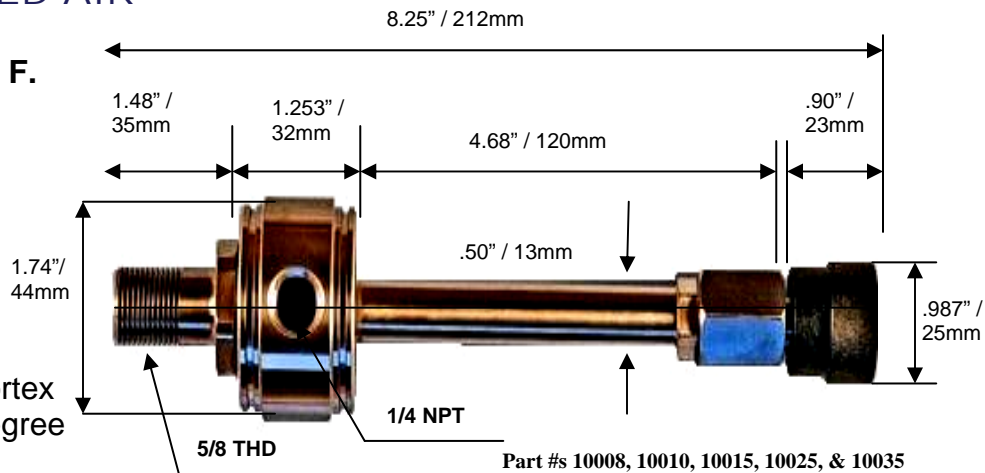

Compressed air is injected circumferentially into the tube at sonic speed and creates a cyclone (Vortex) spinning at a million revolutions per minute. Part of the air is forced to spin inward to the center hole and travels up the long tube where a valve turns the spinning column (Vortex) of air inside itself. The inside column or Vortex of air gives up its heat to the outside vortex or column. The cold air is directed out the cold end of the the Vortex Tube and the hot air is exhausted out of the other end of the Vortex Tube. The temperature and air flow is totally controllable with the adjusting knob.

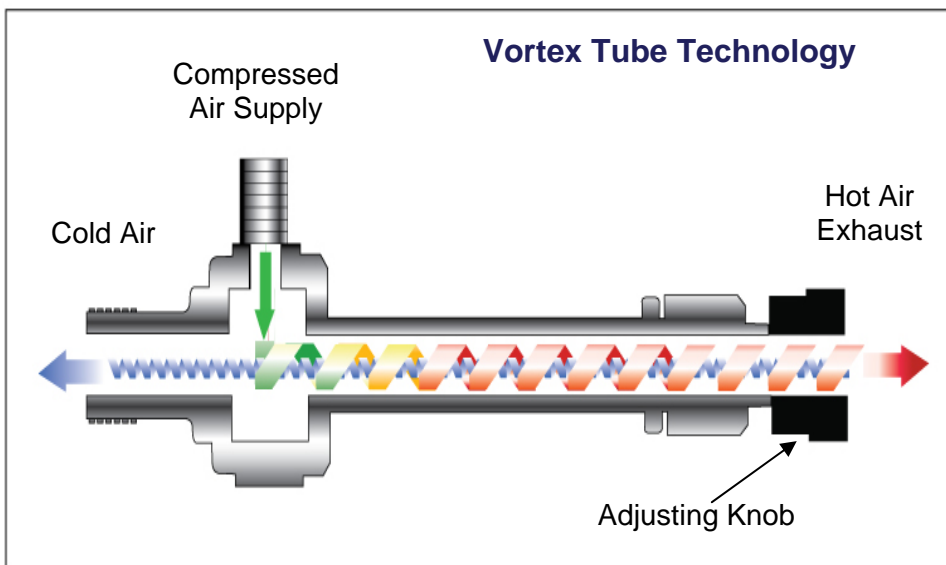

**FEATURES**

- Reliable - No Moving Parts
- Maintenance Free
- Stainless Steel Construction
- No Electricity
- No freon
- Instant On - Controllable
- Compact and Light Weight
- Low Cost

**USES**

- Cool Machining Operations
- Cool Electrical Cabinets
- Cool Mold Tooling
- Cool Sewing Needles
- Cool Hot Operations
- Cool Workers
- Test Thermostats
- Cool CCTV Cameras
- Set Hot Glue Operations

**BENEFITS**

- Spot Cool
- Cool Gas Samples
- Cool Parts
- Cool Heat Sealing
- Cool Molds and Dies
- Cool Processes

**Adjustable & Reliable Cooling!**

# Drop Incoming Air Temperature by up to 100°F

## Arizona Vortex—Vortex Tubes

The Arizona Vortex generator determines the volume of air through the Vortex Tube. These generators are rated for 8,10, 15, 25, and 35 scfm at 80 psig. To ensure that your air compressor can generate these volumes, the horsepower of the compressor can be multiplied by four to determine the scfm capacity. A multiple of 5 can be used on newer compressors.



The Arizona Vortex Tube has no moving parts. Clean compressed air moving through the tube will not cause wear on the parts and will provide you with the same reliable service for an indefinite period of time.

COLD FRACTION	20%	30%	40%	50%	60%	70%	80%
	F°	F°	F°	F°	F°	F°	F°
20 PSIG	63.1	61.3	56.1	51.3	44.5	37	28.8
	15.1	24.4	37.8	51.3	65.1	82.5	108.1
40 PSIG	89.2	85.8	81.1	73.2	63.1	52.5	39.1
	23.4	35.2	52.1	73.2	92.8	116.9	148.1
60 PSIG	104.3	101.7	93.7	84.1	73.5	60.9	45.4
	25.6	39.9	59.1	84.1	104.1	133.1	169.1
80 PSIG	117.1	111.2	102.3	92.2	81.3	66.2	50.1
	26.1	44.1	64.1	92.2	114.1	144.3	181.1
100 PSIG	128.3	119.5	111.1	100.3	86.5	71.9	53.5
	27.8	46.1	67.3	100.3	119.9	151.1	192.1

**Cold Fraction is the percentage of the total flow that comes out as cold air**

**Numbers on the blue line:** Temperature drop from ambient

**Numbers on the red line:** Temperature increase from ambient

**Table information:** compressed air temp:70°F, Dew Point -69°F (Dry Air)

**Backpressure:** Not to exceed 5 PSIG

**Air Flow:** The total SCFM of any vortex tube is proportional to any absolute inlet pressure by calculating:

$$\frac{(\text{PSIG} + 15) \times \text{Generator Rating}}{115} = \text{Approximate Total Air Consumption}$$



Cold Air With Compressed Air!