



Cool Tool Installation and Maintenance



Compressed Air Supply Line Sizes:

To obtain maximum performance from the Arizona Vortex products, measurements of pressure (psig) and volume (scfm) of air must be obtained. Pressure drops in the compressed air lines should be held at a minimum. Quick connects can “starve” the Cool Tool by causing excessive line pressure drops. Do not use plastic tubing. The chart below is suggested lines sizes for pipes and hoses.

Line Sizes for Runs Up To:	10 Ft (3m)		10 - 50 Ft (3 - 15m)		50 - 100 Ft (15 - 31m)	
	Pipe	Hose	Pipe	Hose	pipe	hose
Model #'s 30015 30315	1/4"	3/8"	3/8"	1/2"	1/2"	5/8"

Compressed Air Supply:

Air lines are plagued with condensed water vapor, oil or oil vapor in the air lines. This condensation leads to rust and debris in the air lines. Small orifices in the Arizona Vortex Cool Tool may become clogged with rust, dirt, and water droplets from these unfiltered air supplies. A 5-micron filter will separate 99% of the foreign matter from the air supply, allowing virtually maintenance free operation. The use of an oil filter with an effective filtration of 0.01 ppm will remove the oil droplets for an even cleaner air supply. Air filter part # 90000 can be used with all Arizona Vortex Tubes and other applied models. The Oil Coalescing filter part # 90020 can be used along with the air filter for all Arizona Vortex Tube Products. Keep in mind that the current line or air hose might contain dirt or oil and should be blown out before installation. Also, pipe thread sealant or tape must be carefully applied to avoid clogging product orifices.

Using The Cool Tool:

The Arizona Vortex generator determines the volume of air through the Cool Tool. The generator is an internal plastic part already installed in the Cool Tool. The Cool Tool uses a 15 scfm generator.

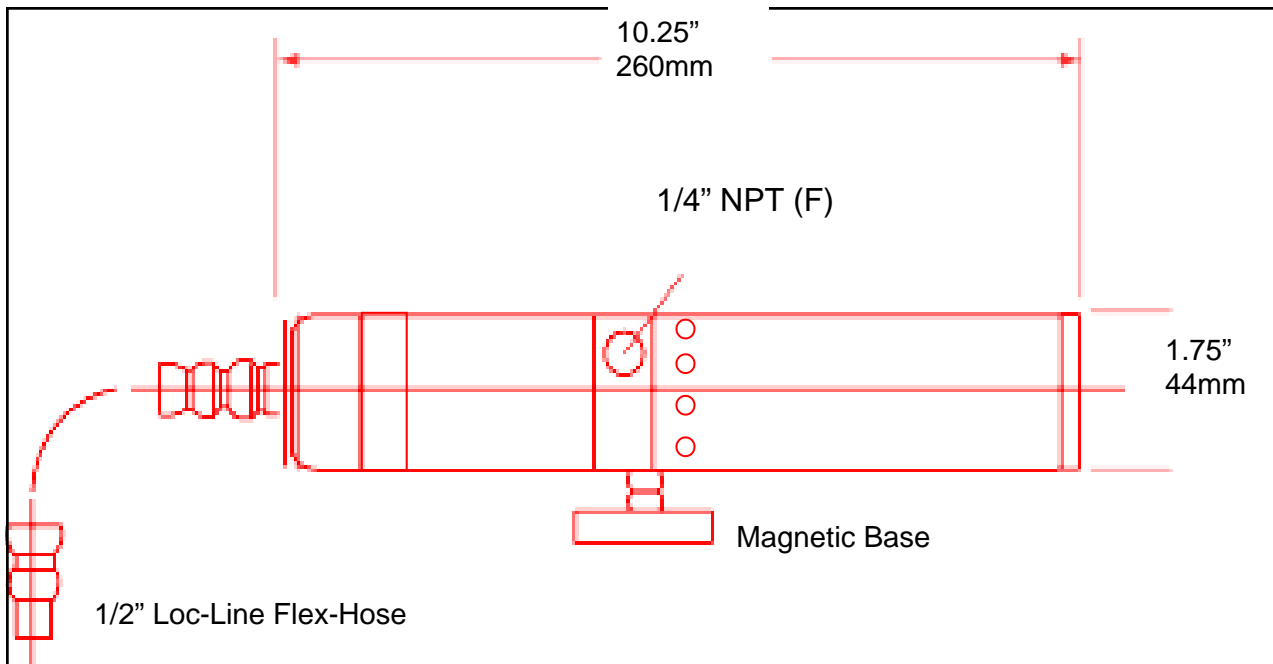

Installation and Mounting:

The Cool Tool is equipped with a magnetic base. Use the magnetic base to place the Cool Tool in a safe area near the area where you need the cold air. Aim the Loc-Line nozzle to the exact location of cooling.

Maintenance:

The Cool Tool has no moving parts. Clean compressed air moving through the unit will not cause any wear. Dirt or moisture will cause problems and will affect the efficiency of the unit. If this happens simply disassemble the unit, clean the parts and reassemble making sure to properly seat the "O" ring and generator.

Trouble-Shooting <i>Common Issues if the Cool Tool has poor performance</i>	Action to Take:
Incoming Air Pressure	Low pressure will cause poor performance. Take a measurement of pressure just before the Cool Tool. Extended lengths of air hose can cause pressure drops and lower performance.
Incoming Air Temperatures	The Cool Tool drops temperature from the compressed air supply. Supply lines may be warmer than ambient if the lines run across the ceiling or near heat ducts.
No Cold Air	Occasionally, dirt, water, or oil may enter the tube from the compressed air supply and hinder the performance. When this happens, simply take the unit apart, clean the parts, and reassemble, tightly replacing the cold end cap to properly seat the generator. When the temperature of the air inside the Arizona Vortex Cool Tool reaches 32° F. (0° C.), the water vapor in the air will start to freeze. If this poses a problem with ice clogging the orifices of the generator inside the tube, an air dryer must be used to lower the dew point to keep out the water vapor. A dryer rated at -35° F will produce a dew point low enough to eliminate the water vapor freezing in the orifices of the generator.

Questions or Concerns:

Toll Free: 1-800-660-4060

Worldwide: 1-928-684-5733

FAX: 1-928-684-5752

Email: info@arizonavortex.com

Website: www.arizonavortex.com